

SR series

Spring Return dosing pumps

B - hydraulic diaphragm type

BR - hydraulic diaphragm type with an internal relief - refilling valve

B
& BR

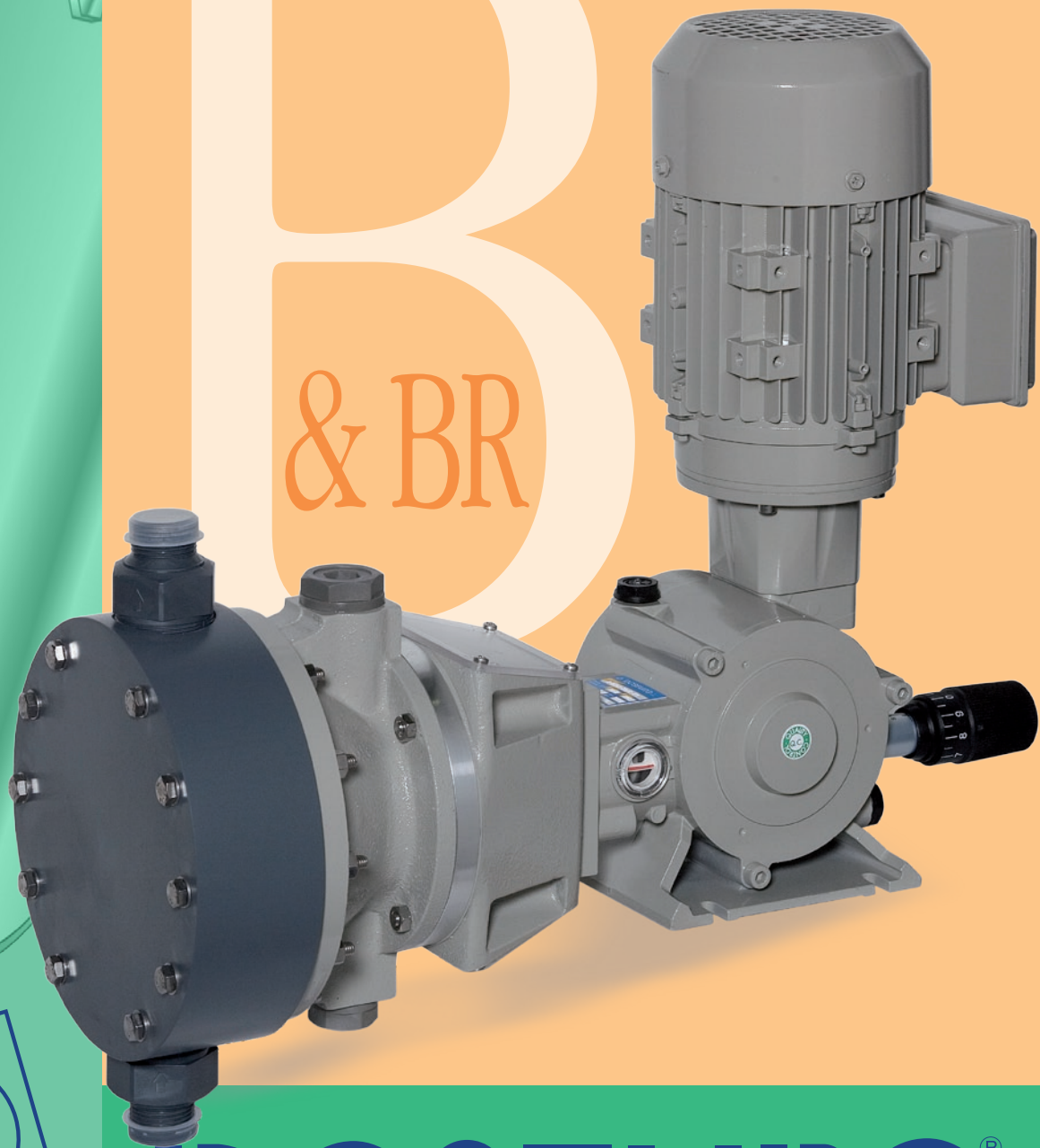

DOSEURO®

The right dosing choice



SR series

MAIN ELEMENTS TO SUPPORT OUR PRODUCTS

Versatility

Different diaphragm sizes are available to suit different applications, starting from 1,5 up to 1068 l/h.

Reliability

The high degree of accuracy and reproducibility with high quality materials selected make the diaphragm pump SR series to assure the maximum reliability.

Quality

The best performance for the applications is achieved by optimal selection of diaphragm material..

FEATURES

Hydraulic Diaphragm metering pumps are suitable for use when the dosed liquid is of abrasive type with small amounts of solids in suspension or is a toxic solution.

Every pump is fitted a standard gearbox reduction system and with vertical mounted B14 shaped electric motor in accordance with the UNEL-MEC specifications.

The motor power range is from 0.18 Kw up to 0.75 Kw at the at European standard: 3 phase voltages of 230/400V @ 50/60Hz, 4 poles and 1 phase voltages of 230/50-60Hz or 110/60Hz.

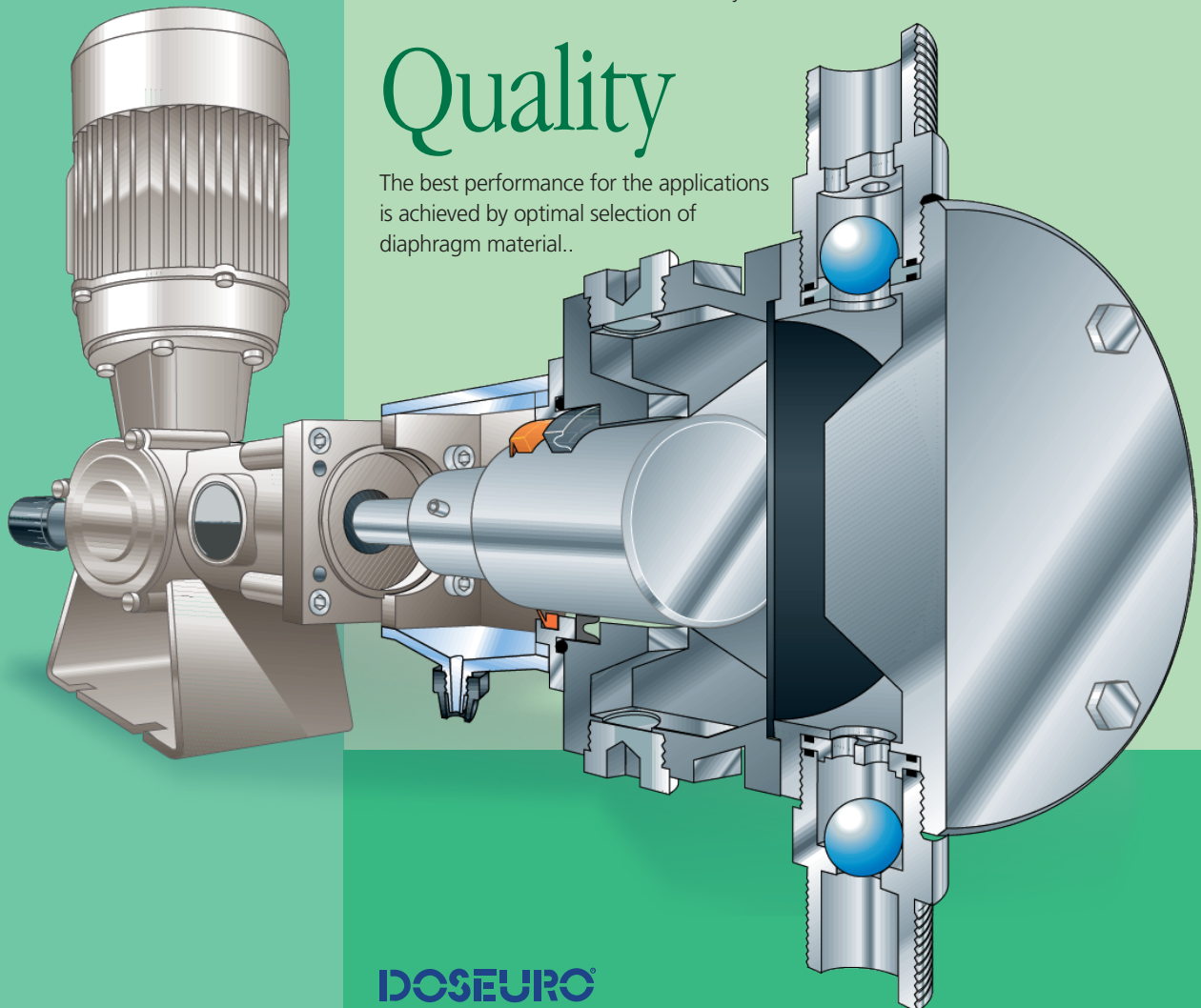

Hydraulic Diaphragm Dosing Pump



B and BR Type

As motors conform to UNEL-MEC specifications, there are many alternative options available, including different voltages, insulation class and special explosion proof versions.

The gearbox is a standard wormwheel reduction system with all bearings supported within a fully lubricated gearbox.

The mechanism for variation of the stroke length is a positive stroke spring return that is operated by an eccentric.

PUMPING HEADS

Pumping heads are made in standard executions: S.S.316 or PVC.

A wide range of other materials like HASTELLOY, ALLOY, PTFE, PVDF, PP are according to the liquid to be dosed.

Standard liquid handled maximum temperature :

- 60 ° C with S.S. 316 pump head
- 40 ° C with PVC pump head

Jacketed pump head for either cooling and heating are available to suit requirements.

DIAPHRAGM

There are made in PTFE/NBR.

SUCTION AND DISCHARGE CONNECTIONS

Normally are threaded, but they can be supplied also UNI or ANSI flanged. All the pumps have a ball valve standard: single and double balls by the function

of the piston diameter or the material execution.

STROKE ADJUSTMENT

Stroke adjustment can be carried out:

- Manual: by a linear micrometer screw.
- Electrical: via servo motor with 4-20 mA signal upon request interface PROFIBUS or other BUS.
- Pneumatic: by a pneumatic servo control with signal from 3 to 15 PSI.

Flow rate adjustment is possible while running or standstill.

MULTIPLE HEADED PUMPS

Different multiple heads units are available on request.

Each pumping element has independent adjustment while running or at standstill.

"B" AND "BR" SERIES HYDRAULIC DIAPHRAGM PUMPS ARE AVAILABLE IN DIFFERENT SIZES:

- B 125N / BR 125N
Stroke length 12.5 mm
- B 175N / BR 175N
Stroke length 17.5 mm
- B 250N / BR 250N
Stroke length 25 mm

For these three types, different diaphragm sizes are available to suit different applications for capacity and pressure.

Execution 41

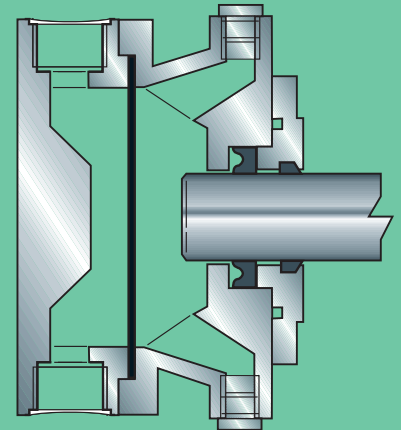

Execution 43

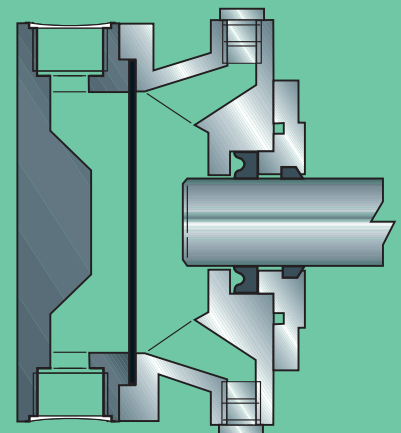

Execution 41 for BR pump

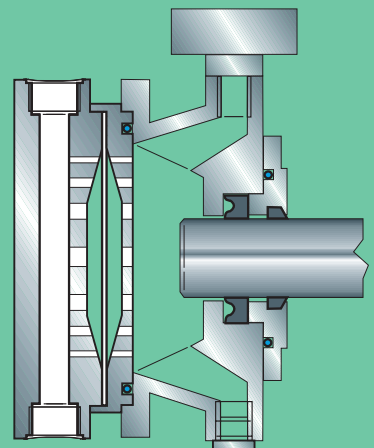



SR series

SOME STANDARD EXECUTIONS FOR HYDRAULIC DIAPHRAGM PUMPS

EXECUT.	PUMPHEAD	PISTON	VALVE (ball)	VALVE SEAT	DIAPHRAGM	VALVE GASKETS
29	PP	S.S. 420 TEMP.	PYREX	PP	PTFE/NBR	T20
41	S.S. 316	S.S. 420 TEMP.	S.S. 316	S.S. 316	PTFE/NBR	T20
43	PVC	S.S. 420 TEMP.	PYREX	PVC	PTFE/NBR	T20

PP = Polypropylene
 S.S. 316 = Stainless steel 316
 S.S. 420 TEMP. = Tempered stainless steel 420
 T20 = Polyurethane rubber

Different executions on request

Glossary and numbering system to identify pumps type

B	125N	30	B	41	DV
1st group	2nd group	3rd group	1th group	1th group	1th group
"B" series Hydraulic diaphragm dosing pump	Stroke length	Diaphragm diameter in mm	Reduction ratio group (n° of strokes/min) 58=F(1/24) 116=B (1/12)	Materials in touch with the fluid	Not standard-special code

In case of pumps supplied without motor add: W/M

OVERALL DIMENSIONS

	125	175	250
A	57	68	75
B	90	100	127
C	70	70	120
D	75	73	70
E	375	410	450
F	90	90	154
G	75	75	130
H	115	125	157
I	65	65	102
L	7	7	9
M	130	170	194
N	33	33	60
O	80	78	78

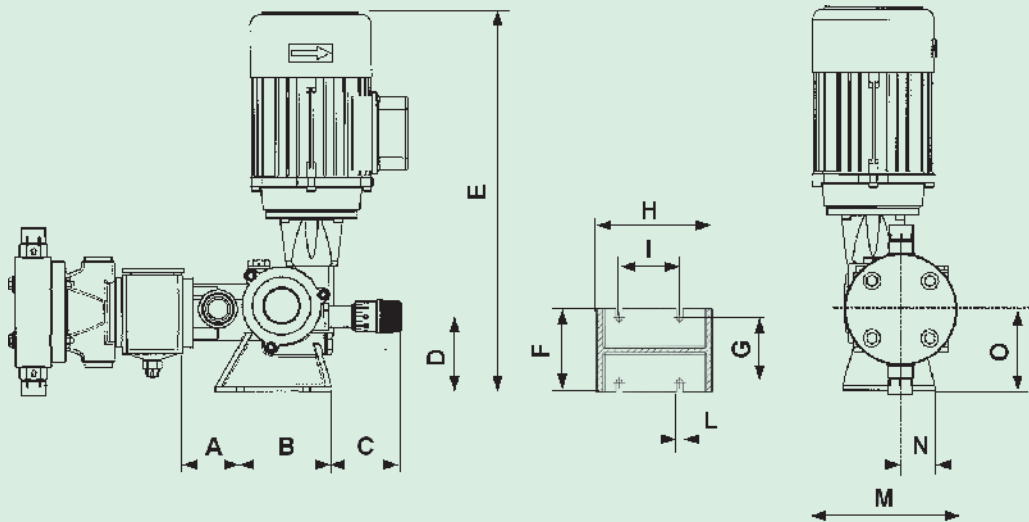

General dimensional quote are indicative and adverted to the maximum acceptable pump dimension

Spring Return Hydraulic Diaphragm Dosing Pumps

Type B 125N



TECHNICAL FEATURES

Pump type	Reducer ratio		Capacity (*2)				Max Press. Kg/cm ² (*3)				Connect. (*4) SS 316 or PVC	Motor features	ø mm		Stroke length	Net weights Kg (*5)		
	(*1)	SPM (*1)		L/l'		L/h		SS 316		PVC			Real piston	Diaphragm.		SS 316	PVC	
		50 Hz	60 Hz	50 Hz	60 Hz	50 Hz	60 Hz	0,18 kW	0,25 kW	0,18 kW	0,25 kW	1/2" G.m.	0.18 kW or 0.25 kW	25	70	12.5 mm	10	9,5
B-125N-8	F	58	70	0,025	0,030	1,5	1,8	20 *	-	10	-	1/2" G.m.	0.18 kW or 0.25 kW	8	50	12.5 mm	9,5	8
	C	96	116	0,040	0,050	2,4	3							12			9,5	8
	B	116		0,050		3												
B-125N-12	I	35	42	0,045	0,054	2,7	3,2	20 *	-	10	-	1/2" G.m.	0.18 kW or 0.25 kW	12	50	12.5 mm	9,5	8
	F	58	70	0,075	0,090	4,5	5,4											
	C	96	116	0,123	0,150	7,4	9											
B-125N-18	I	35	42	0,110	0,132	6,6	7,9	20 *	-	10	-	1/2" G.m.	0.18 kW or 0.25 kW	18	50	12.5 mm	10	9,5
	F	58	70	0,183	0,220	11	13,2											
	C	96	116	0,300	0,366	18	22											
B-125N-25	I	35	42	0,211	0,252	12,6	15,1	20 *	-	10	-	1/2" G.m.	0.18 kW or 0.25 kW	25	70	12.5 mm	10	9,5
	F	58	70	0,350	0,420	21	25,2											
	C	96	116	0,566	0,700	34	42											
B-125N-30	I	35	42	0,301	0,360	18	21,6	14	20 *	10	-	1/2" G.m.	0.18 kW or 0.25 kW	30	70	12.5 mm	10	9,5
	F	58	70	0,500	0,600	30	36											
	C	96	116	0,816	1,000	49	60											
B-125N-40	I	35	42	0,543	0,650	32,5	39	8	13,2	8	10	1/2" G.m.	0.18 kW or 0.25 kW	40	90	12.5 mm	11	11
	F	58	70	0,900	1,080	54	65											
	C	96	116	1,483	1,800	89	108											
	B	116		1,800		108												

(*1) Piston's strokes number during 1 minute with 4 poles installed motor (~1400 rpm)

I = Reducer ratio 1 : 40 = 35 strokes at 60 Hz / 42 strokes at 60 Hz
 F = Reducer ratio 1 : 24 = 58 strokes at 50 Hz / 70 strokes at 60 Hz
 C = Reducer ratio 1 : 14,5 = 96 strokes at 50 Hz / 116 strokes at 60 Hz
 B = Reducer ratio 1 : 12 = 116 strokes at 50 Hz / not suitable

(*2) The indicated capacity value is subject to changes due to the working pressure, the dosed liquid, the viscosity and the installation asset.

(*3) For higher pressure please contact our sales department.

(*4) Different ranges of connections are available on request

(*5) The weight is approximate and is the value of the pump fitted with a totally enclosed fan-cooled outdoor motor.

(*6) The pumps can be supplied with accessories if requested.

(*7) The pumps are epoxy painted RAL 7030



SR series

Type B 175N

TECHNICAL FEATURES

Pump type	Reducer ratio			Capacity (*2)				Max Press. Kg/cm ² (*3)				Connect. (*4) SS 316 or PVC	Motor features	ø mm Real piston	ø mm Diaphrag.	Stroke length	Net weights Kg (*5)		
	(*1)	SPM (*1)		L/1'		L/h		SS 316		PVC							SS 316 PVC	SS 316	PVC
		50 Hz	60 Hz	50 Hz	60 Hz	50 Hz	60 Hz	0,25 kW	0,37 kW	0,25 kW	0,37 kW								
B-175N-8	F	70	84	0,043	0,052	2,6	3,12	20 *	-	10	1/2" G.m.	0.25 kW or 0.37 kW	8	50	17.5 mm	11,5	11		
	C	96	116	0,058	0,070	3,5	4,2												
	B	120		0,073		4,4													
B-175N-12	F	70	84	0,126	0,152	7,6	9,12	20 *	-	10	1/2" G.m.	0.25 kW or 0.37 kW	12	50	17.5 mm	12	11,5		
	C	96	116	0,173	0,206	10,4	12,4												
	B	120		0,216		13													
B-175N-18	F	70	84	0,300	0,360	18	21,6	20 *	-	10	1/2" G.m.	0.25 kW or 0.37 kW	18	50	17.5 mm	12	11,5		
	C	96	116	0,400	0,480	24	28,8												
	B	120		0,533		32													
B-175N-25	F	70	84	0,600	0,720	36	43,2	20 *	-	10	1/2" G.m.	0.25 kW or 0.37 kW	25	70	17.5 mm	12,5	12		
	C	96	116	0,816	0,980	49	58,8												
	B	120		1,016		61													
B-175N-30	F	70	84	0,850	1,020	51	61,2	20 *	-	10	1/2" G.m.	0.25 kW or 0.37 kW	30	70	17.5 mm	12,5	12		
	C	96	116	1,150	1,380	69	82,8												
	B	120		1,466		88													
B-175N-40	F	70	84	1,533	1,840	92	110,4	12	20	10	1/2" G.m.	0.25 kW or 0.37 kW	40	90	17.5 mm	13,5	12		
	C	96	116	2,100	2,52	126	151,2												
	B	120		2,630		158													
B-175N-50	F	70	84	2,400	2,880	144	172,8	7,5	11	10	1/2" G.m.	0.25 kW or 0.37 kW	50	120	17.5 mm	16	15		
	C	96	116	3,283	3,940	197	236,4												
	B	120		4,116		247													
B-175N-55	F	70	84	2,900	3,480	174	208,8	6,3	11	10	3/4" G.m.	0.25 kW or 0.37 kW	55	120	17.5 mm	16	15		
	C	96	116	3,966	4,760	238	285,6												
	B	120		4,983		299													
B-175N-65	F	70	84	4,050	4,860	243	291,6	4,5	7,8	7,8	3/4" G.m.	0.25 kW or 0.37 kW	65	120	17.5 mm	16	15		
	C	96	116	5,550	6,660	333	399,6												
	B	120		6,960		418													

(*1) Piston's strokes number during 1 minute with 4 poles installed motor (~1400 rpm 1')

F = Reducer ratio 1 : 20 = 70 strokes at 50 Hz / 84 strokes at 60 Hz

C = Reducer ratio 1 : 14,5 = 96 strokes at 50 Hz / 116 strokes at 60 Hz

B = Reducer ratio 1 : 11,5 = 120 strokes at 50 Hz / not suitable

(*2) The indicated capacity value is subject to changes due to the working pressure, the dosed liquid, the viscosity and the installation asset.

(*3) For higher pressure please contact our sales department

(*4) Different ranges of connections are available on request

(*5) The weight is approximate and is the value of the pump fitted with a totally enclosed fan-cooled outdoor motor.

(*6) The pumps can be supplied with accessories if requested

(*7) The pumps are epoxy painted RAL 7030

DOSEURO

Spring Return Hydraulic Diaphragm Dosing Pumps

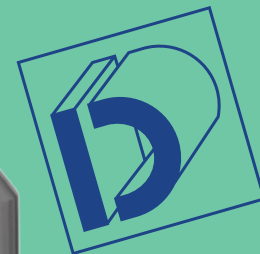

Type B 250N



TECHNICAL FEATURES

Pump type	Reducer ratio		Capacity (*2)				Max Press. Kg/cm ² (*3)				Connect. (*4)	Motor features	ø mm		Stroke length	Net weights Kg (*5)		
	(*1)	SPM (*1)		L/1'		L/h		SS 316		PVC			Real piston	Diaphrag.		Kg (*5)		
		50 Hz	60 Hz	50 Hz	60 Hz	50 Hz	60 Hz	0,55 kW	0,75 kW	0,55 kW	0,75 kW					SS 316 or PVC	SS 316	PVC
B-250N-40	F	56	67	1,75	2,10	105	126	11 *	-	10	-	3/4" G.m.	0,55 kW or 0,75 kW	40	120	25 mm	26	23
	C	96	116	3,00	3,60	180	216										26	23
	B	112		3,50		210											26	23
B-250N-50	F	56	67	2,75	3,30	165	198	11 *	-	10	-	3/4" G.m.	0,55 kW or 0,75 kW	50	120	25 mm	26	23
	C	96	116	4,70	5,63	282	338										26	23
	B	112		5,50		330											26	23
B-250N-55	F	56	67	3,33	4,00	200	240	11 *	-	10	-	3/4" G.m.	0,55 kW or 0,75 kW	55	120	25 mm	26	23
	C	96	116	5,70	6,83	342	410										26	23
	B	112		6,66		400											26	23
B-250N-65	F	56	67	4,63	5,56	278	333,6	9 *	-	9	-	1" G.m.	3 Ph or 1 Ph ~1400 rpm	65	160	25 mm	37	26
	C	96	116	7,93	9,52	476	571,2										37	26
	B	112		9,26		556											37	26
B-250N-75	F	56	67	6,18	7,42	371	445,2	6,6	8,7	6,6	8,7	1" G.m.	3 Ph or 1 Ph ~1400 rpm	75	160	25 mm	37	26
	C	96	116	10,60	12,72	636	763,2										37	26
	B	112		12,36		742											37	26
B-250N-90	F	56	67	8,90	10,68	534	640,8	4,7	6,2	4,7	6,2	1" G.m.	3 Ph or 1 Ph ~1400 rpm	90	25 mm	37	26	
	C	96	116	15,25	18,30	915	1098									37	26	
	B	112		17,80		1068										37	26	

(*1) Piston's strokes number during 1 minute with 4 poles installed motor (~1400 rpm 1')

F = Reducer ratio 1 : 25 = 56 strokes at 50 Hz / 67 strokes at 60 Hz

C = Reducer ratio 1 : 14,5 = 96 strokes at 50 Hz / 116 strokes at 60 Hz

B = Reducer ratio 1 : 12,5 = 112 strokes at 50 Hz / not suitable

(*2) The indicated capacity value is subject to changes due to the working pressure, the dosed liquid, the viscosity and the installation asset.

(*3) For higher pressure please contact our sales department.

(*4) Different ranges of connections are available on request

(*5) The weight is approximate and is the value of the pump fitted with a totally enclosed fan-cooled outdoor motor.

(*6) The pumps can be supplied with accessories if requested

(*7) The pumps are epoxy painted RAL 7030



SR series

Type BR 125N

Pump type	Reducer ratio		Capacity (*2)				Max Press. Kg/cm ² (*3)				Connect. (*4)	Motor features	ø mm Real piston	ø mm Diaphrag.	Stroke length	Net weights Kg (*5)	
	(*1)	SPM (*1)		L/1'		L/h		SS 316		PVC						SS 316 or PVC	SS 316
		50 Hz	60 Hz	50 Hz	60 Hz	50 Hz	60 Hz	0,18 kW	0,25 kW	0,18 kW	0,25 kW						
BR-125N-8	F	58	70	0,025	0,030	1,5	1,8	13,5 *	-	7	-	0,18 kW or 0,25 kW	8	50	12,5 mm	10,5	9
	C	96	116	0,040	0,050	2,4	3										
	B	116		0,050		3											
BR-125N-12	I	35	42	0,045	0,054	2,7	3,2	13,5 *	-	7	-	0,18 kW or 0,25 kW	12	50	12,5 mm	10,5	9
	F	58	70	0,075	0,090	4,5	5,4										
	C	96	116	0,123	0,150	7,4	9										
BR-125N-18	I	35	42	0,110	0,132	6,6	7,9	13,5 *	-	7	-	0,18 kW or 0,25 kW	18	70	12,5 mm	11	10,5
	F	58	70	0,183	0,220	11	13,2										
	C	96	116	0,300	0,366	18	22										
BR-125N-25	I	35	42	0,211	0,252	12,6	15,1	13,5 *	-	7	-	0,18 kW or 0,25 kW	25	70	12,5 mm	11	10,5
	F	58	70	0,350	0,420	21	25,2										
	C	96	116	0,566	0,700	34	42										
BR-125N-30	I	35	42	0,301	0,360	18	21,6	9	13,5 *	7	-	0,18 kW or 0,25 kW	30	70	12,5 mm	11	10,5
	F	58	70	0,500	0,600	30	36										
	C	96	116	0,816	1,000	49	60										
BR-125N-40	I	35	42	0,543	0,650	32,5	39	5	8,5	5	7	0,18 kW or 0,25 kW	40	90	12,5 mm	12	12
	F	58	70	0,900	1,080	54	65										
	C	96	116	1,483	1,800	89	108										
	B	116		1,800		108											



(*1) Numero di colpi effettuati al minuto dal pistone - motore a 4 poli. (~1400 giri 1')

BR 125N I = Reducer ratio 1 : 40 = 35 strokes at 60 Hz / 42 strokes at 60 Hz
 F = Reducer ratio 1 : 24 = 58 strokes at 50 Hz / 70 strokes at 60 Hz
 C = Reducer ratio 1 : 14,5 = 96 strokes at 50 Hz / 116 strokes at 60 Hz
 B = Reducer ratio 1 : 12 = 116 strokes at 50 Hz / not suitable

BR 175N F = Reducer ratio 1 : 25 = 56 strokes at 50 Hz / 67 strokes at 60 Hz
 C = Reducer ratio 1 : 14,5 = 96 strokes at 50 Hz / 116 strokes at 60 Hz
 B = Reducer ratio 1 : 12,5 = 112 strokes at 50 Hz / not suitable

BR 250N F = Reducer ratio 1 : 25 = 56 strokes at 50 Hz / 67 strokes at 60 Hz
 C = Reducer ratio 1 : 14,5 = 96 strokes at 50 Hz / 116 strokes at 60 Hz
 B = Reducer ratio 1 : 12,5 = 112 strokes at 50 Hz / not suitable

(*2) The indicated capacity value is subject to changes due to the working pressure, the dosed liquid, the viscosity and the installation asset.

(*3) For higher pressure please contact our sales department.

(*4) Different ranges of connections are available on request

(*5) The weight is approximate and is the value of the pump fitted with a totally enclosed fan-cooled outdoor motor.

(*6) The pumps can be supplied with accessories if requested

(*7) The pumps are epoxy painted RAL 7030

DOSEURO

Spring Return Hydraulic Diaphragm Dosing Pumps



Type BR 175N

Pump type	Reducer ratio			Capacity (*2)				Max Press. Kg/cm ² (*3)				Connect. (*4)	Motor features	ø mm Real piston	ø mm Diaphragm	Stroke length	Net weights Kg (*5)				
	(*1)	SPM (*1)		L/1'		L/h		SS 316		PVC							SS 316 or PVC	SS 316	PVC		
		50 Hz	60 Hz	50 Hz	60 Hz	50 Hz	60 Hz	0,25 kW	0,37 kW	0,25 kW	0,37 kW										
BR-175N-8	F	70	84	0,043	0,052	2,6	3,12	14	*	7	-	1/2" G.m.	0,25 kW or 0,37 kW	8	50	17,5 mm	12,5	12			
	C	96	116	0,058	0,070	3,5	4,2														
	B	120		0,073		4,4															
BR-175N-12	F	70	84	0,126	0,152	7,6	9,12	14	*	7	-			0,25 kW or 0,37 kW			12	50	17,5 mm	13	12,5
	C	96	116	0,173	0,206	10,4	12,4														
	B	120		0,216		13															
BR-175N-18	F	70	84	0,300	0,360	18	21,6	14	*	7	-		0,25 kW or 0,37 kW		18	50	17,5 mm			13	12,5
	C	96	116	0,400	0,480	24	28,8														
	B	120		0,533		32															
BR-175N-25	F	70	84	0,600	0,720	36	43,2	14	*	7	-			0,25 kW or 0,37 kW	25			70	17,5 mm	13,5	13
	C	96	116	0,816	0,980	49	58,8														
	B	120		1,016		61															
BR-175N-30	F	70	84	0,850	1,020	51	61,2	14	*	7	-	0,25 kW or 0,37 kW	30		70	17,5 mm	13,5			13	
	C	96	116	1,150	1,380	69	82,8														
	B	120		1,466		88															
BR-175N-40	F	70	84	1,533	1,840	92	110,4	9	13	7	-		~1400 rpm	40			90	17,5 mm	14,5	13	
	C	96	116	2,100	2,52	126	151,2														
	B	120		2,630		158															
BR-175N-50	F	70	84	2,400	2,880	144	172,8	5	7	5	7	3/4" G.m.		50	120	17,5 mm			17	16	
	C	96	116	3,283	3,940	197	236,4														
	B	120		4,116		247															
BR-175N-55	F	70	84	2,900	3,480	174	208,8	4	7	4	7		3/4" G.m.	55			120	17,5 mm	17	16	
	C	96	116	3,966	4,760	238	285,6														
	B	120		4,983		299															
BR-175N-65	F	70	84	4,050	4,860	243	291,6	3	5	3	5	3/4" G.m.		65	120	17,5 mm			17	16	
	C	96	116	5,550	6,660	333	399,6														
	B	120		6,960		418															

Type BR 250N

Pump type	Reducer ratio			Capacity (*2)				Max Press. Kg/cm ² (*3)				Connect. (*4)	Motor features	ø mm Real piston	ø mm Diaphragm	Stroke length	Net weights Kg (*5)				
	(*1)	SPM (*1)		L/1'		L/h		SS 316		PVC							SS 316 or PVC	SS 316	PVC		
		50 Hz	60 Hz	50 Hz	60 Hz	50 Hz	60 Hz	0,55 kW	0,75 kW	0,55 kW	0,75 kW										
BR-250N-40	F	56	67	1,75	2,10	105	126	7,2 *	-	7	-	3/4" G.m.	0,55 kW or 0,75 kW	40	120	25 mm	27	24			
	C	96	116	3,00	3,60	180	216														
	B	112		3,50		210															
BR-250N-50	F	56	67	2,75	3,30	165	198	7,2 *	-	7	-			0,55 kW or 0,75 kW			50	120	25 mm	27	24
	C	96	116	4,70	5,63	282	338														
	B	112		5,50		330															
BR-250N-55	F	56	67	3,33	4,00	200	240	7,2 *	-	7	-		0,55 kW or 0,75 kW		55	120	25 mm			27	24
	C	96	116	5,70	6,83	342	410														
	B	112		6,66		400															
BR-250N-65	F	56	67	4,63	5,56	278	333,6	5,9 *	-	5,9	-			~1400 rpm	65			160	25 mm	38	27
	C	96	116	7,93	9,52	476	571,2														
	B	112		9,26		556															
BR-250N-75	F	56	67	6,18	7,42	371	445,2	4,3	5,7	4,3	5,7	1" G.m.	75		160	25 mm	38			27	
	C	96	116	10,60	12,72	636	763,2														
	B	112		12,36		742															
BR-250N-90	F	56	67	8,90	10,68	534	640,8	3,1	4	3,1	4		1" G.m.	90			160	25 mm	38	27	
	C	96	116	15,25	18,30	915	1098														
	B	112		17,80		1068															



Accessories

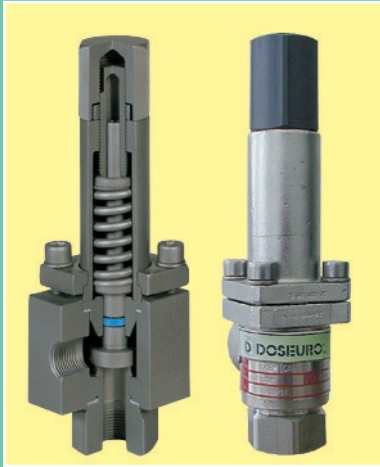

Safety relief valves

Type	Pump capacity	Connections
TS-10	200 l/h	3/8" or 1/2"
TS-13	400 l/h	1/2" G.F
TS-21	1000 l/h	1" G.F
Body	PVC or S.S. 316	

* S.S. 316 Relief - Safety valve setting pressure: max 40 kg/cm² (588 Psi) higher pressures are available on request.
PVC Relief safety valve setting pressure: max 10 kg/cm² (145 Psi).
For higher setting pressures consult our technical dept.



Pulsation dampeners

Type: HSTX
Body in S.S.316, composed of two parts assembled by a special hosing that under dynamic pressures tends to close itself. Diaphragms are compatible to the liquid used. Built in accordance with ASME VIII° Div. 1 rules.



Type: HSTPVC
Body in PVC, composed of two parts assembled by a special hosing that under dynamic pressures tends to close itself. Maximum temperature: + 50 °C. Diaphragms are compatible with the process liquid.

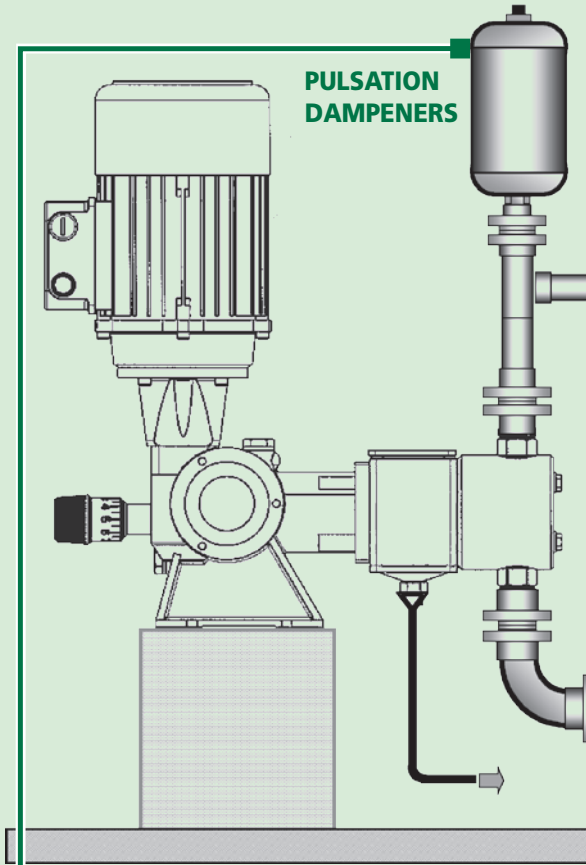

Each metering pump can be supplied with accessories in order to improve the operation and accuracy of the units.

The benefits of fluid control assure

- Increase efficiency and pump life
- Decrease maintenance and operation costs

The control of fluid dynamics is essential to ensure efficient and safe use of process systems. Uncontrolled fluid in motion can physically destroy. A pumping system including the pumping, valves, meters, back pressure valves, inline instrumentation and equipment.

1.- FILTERS

We suggest to install filters (on the suction pipe) to keep back impurities that can be presented on liquid to be dosed or coming from pipeline system.

The use of filters assures a trouble-free dosing.

2.- SAFETY VALVES

Safety valves are designed to protect the pump and chemical feed system from over pressure damage caused by defective equipment or a blockage in the chemical feed line.

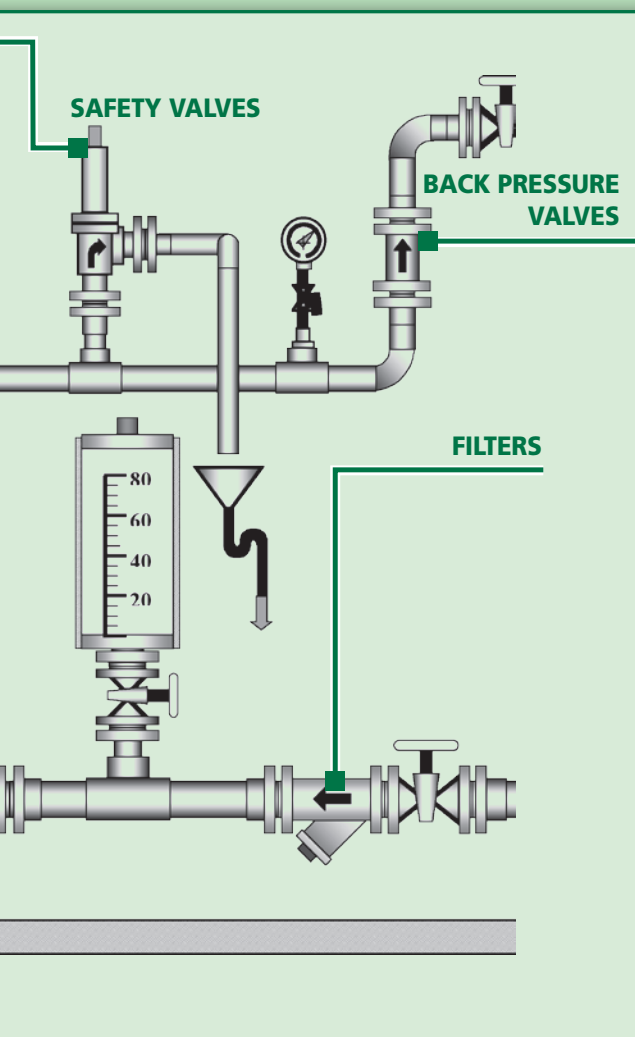
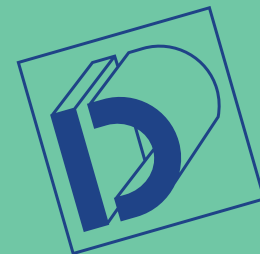

Relief valves

Type	Pump Capacity	Connections
VSCS-6	90 l/h	1/2" G.F
VSCS-10	230 l/h	1/2" G.F
VSCS-14	420 l/h	3/4" G.F
VSCS-22	1050 l/h	1" G.F

Body	PVC, PP or S.S. 316
Diaphragm	PTFE/NBR

* Relief valve setting pressure:
3/10 kg/cm² (44/145 Psi)
G.F.= Cylindrical, Female



Back pressure valves

Type	Pump Capacity	Connections
VSCC-6	90 l/h	1/2" G.F
VSCC-10	230 l/h	1/2" G.F
VSCC-14	420 l/h	3/4" G.F
VSCC-22	1050 l/h	1" G.F

Body	PVC, PP or S.S. 316
Diaphragm	PTFE/NBR

* Back pressure valve setting pressure:
1/3 kg/cm² (15/44Psi)
G.F.= Cylindrical, Female



3.- BACK PRESSURE VALVES

Back pressure valves apply positive discharge pressure to a metering pump system to prevent siphoning and eliminate varying downstream pressure.

4.- PULSATION DAMPENER

Metering pumps have a pulsating flow. Both spring return plunger dosing pumps and quick closing valves start and stop fluids that are in motion. Spring return plunger dosing pumps derive their pumping action by capturing a given amount of fluid in a chamber and pushing it out the pump's discharge.

Each pump cycle includes a suction stroke during the fluid flow is stopped.

This pumping action produces an acceleration/deceleration of the fluid, creating units of uncontrolled energy, resulting in PULSATION, observed as pressure spikes.

Pulsation dampener is required for two reasons:

- To reduce high, non-permissible pressure fluctuations.
- To create a nearly continuous flow.

Polyethylene tanks

suitable to be fitted with metering pump on its top





Our range of production also includes:

SR Series Spring Return:

Piston dosing pumps: type "A" and "AP-A"
Mechanical diaphragm dosing pumps: type "D" and "FM"

PDP Series:

Positive displacement dosing pumps: type "AI" and "AP-AI"
Positive displacement dosing pumps: type "BI" and "SDI"

SDP Series:

Solenoid dosing pumps: type "S"
Solenoid dosing pumps: type "GA"

H Series:

Automatic plants for dissolution and preparation of powder polyelectrolytes:
type "HA" - "HB" - "HE" and "HA-P"

EM Series:

Electric Mixers for chemical mixing:
type "DAM", "DMT", "DEM", "DRV", "DRC" and "DVL"



Cert. n° 5942

HEAD OFFICE

Via G. Carducci 141
20093 Cologno Monzese (MI) Italy
Tel.: +39 02 27301324
Fax: +39 02 26700883
e-mail: info@doseuro.com
www.doseuro.com

DOSEURO (UK) LTD.

Unit 8, East Road Industrial Estate
Sleaford, Lincolnshire NG34 7EH
Tel.: +44 1529 300045
Fax: +44 1529 410967
e-mail: enquiries@doseuro.co.uk
www.doseuro.co.uk



DOSEURO®
The right dosing choice